



THISTLE MIDWINTERS EAST REGATTA

Fort Walton Beach, FL March 8th – March 12th, 2025

The organizing authorities for this event are the Thistle Class Association and the Fort Walton Yacht Club.

SAILING INSTRUCTIONS

1. RULES

- 1.1. The regatta will be governed by the rules as defined in the current Racing Rules of Sailing (RRS) and the Thistle Class Rules.
- 1.2. The US Sailing prescriptions to the Preamble to Part 5, Section B and to RRS 63.1(b) shall not apply.

2. NOTICES TO COMPETITORS

- 2.1. Notices to competitors will be posted on the Official Notice Board located at [NextSailor](https://www.nextsailor.com/app/page/regatta/817) (<https://www.nextsailor.com/app/page/regatta/817>) and may also be posted on the back porch of FWYC. Failure to post a physical notice will not be grounds for redress. This changes RRS 61.4(b)(1).

3. CHANGES TO SAILING INSTRUCTIONS

- 3.1. Any written change to the sailing instructions will be posted at least 1.5 hours before the scheduled start of the day's racing.
- 3.2. Any change to the schedule of races will be posted by 2000 on the day before it will take effect.
- 3.3. If necessary, changes to the sailing instructions may be made on the water. The Signal Vessel will signal "come within hail" by displaying Flag L with one sound. Each boat will receive and acknowledge the oral change. These changes will be posted on the [ONB](#) as soon as practicable.

4. SIGNALS MADE ASHORE

- 4.1. Signals made ashore will be displayed at the flagpole on the west lawn of FWYC.
- 4.2. If a postponement is signaled ashore, the warning signal will be made not less than 60 minutes after Flag AP is lowered. This changes Race Signals "AP."

5. SCHEDULE OF RACES

- 5.1. Saturday March 8th
1300-1630 Registration and Competitor Check in
1700 Competitors Briefing

Sunday March 9th
0900 Competitors briefing
1100 Warning, 1st race of the day
Monday March 10th
0900 Competitors briefing
1100 Warning, 1st race of the day
Tuesday March 11th
0900 Competitors briefing
1100 Warning, 1st race of the day
Wednesday March 12th
0900 Competitors briefing
1100 Warning, 1st race of the day
1430 – No Warning Signal after this time.

5.2. The RC may run as many as three races per day, except on the last day of racing when the RC may run as many as two races.

6. CLASS FLAG

6.1. The class flag will be a Thistle Class pennant.

7. RACING AREA

7.1. The racing area will be on Choctawhatchee Bay east of the Yacht Club.

8. COURSES

8.1. SI Addendum 1 shows the course designations and the order in which Marks are to be passed.

8.2. The course, bearing and the approximate distance to Mark W will be displayed from the RC signal boat and announced on VHF Channel 72.

9. MARKS

9.1. Marks W and O will be an orange tetrahedron and orange ball respectively. Marks LS, LP, (gate Marks) will be green tetrahedrons, and R will be a large orange inflatable. The finish pin will be an orange inflatable triangle.

9.2. To change the weather Mark, the change Mark will be a yellow tetrahedron and an orange ball as Mark O. To change the leeward Gate, the RC will move existing LS and LP to the new location.

10. THE START

10.1. The starting line will be between the staff displaying an orange flag on the RC signal vessel and a staff displaying an orange flag on the pin end vessel.

10.2. At least five minutes prior to the warning signal of a race, the RC will display the orange starting line flags.

10.3. The Race Committee may sound an attention signal of a series of horn blasts one minute prior to the warning signal.

10.4. The Race Committee shall, after the starting signal, attempt to hail the sail number of boats who are OCS, UFD, or BFD on the VHF Channel identified in SI 18.3. The delay of such a hail, the order of the hail or the failure of a competitor to hear such a hail, shall not be grounds for granting redress; this changes RRS 61.4(b)(1).

10.5. A boat starting later than 4 minutes after her starting signal will be scored DNS without a hearing. This changes A4, A5 and 61.4(b)(1).

11. CHANGING THE NEXT LEG OF THE COURSE

- 11.1. To change the next leg of the course, the Race Committee will change the position of the next Mark as soon as practicable in accordance with RRS 33.
- 11.2. The angle of the gate may be adjusted without making any signals. This changes RRS Race Signals.
- 11.3. The Race Committee can change a Mark by up to 10 degrees or 0.1 nm without signaling a change. Such change shall be announced over VHF 72. This changes RRS 33.
- 11.4. The RC may shorten any course provided that the first two upwind legs of the course have been completed (not including the weather Mark to offset Mark).

12. THE FINISH

- 12.1. The finishing line will be between a staff displaying an orange flag on the RC finish boat and the course side of the nearby finishing Mark. This changes RRS Race Signals "Blue flag".

13. TIME LIMITS

- 13.1. If no boat has passed Mark W within twenty-five (25) minutes of their start, or if or if no boat finishes within ninety (90) minutes of their start, the race shall be abandoned.
- 13.2. Provided that a competitor has Sailed the Course and Finished within the Time Limits above, boats failing to Finish within twenty (20) minutes after the first boat in a race Finishes (the Finish Window) will be scored "Time Limit Expired" (TLE). TLE will be defined as the average score of all boats not Finished and still Sailing the Course at the close of the Finish Window. If fewer than 33% of competitors have Finished within the Finish Window, the race shall be Abandoned. This changes RRS 32, 35, 61.1(a), 61.4(b)(1), A4, and A5.
- 13.3. The Race Committee may score a boat or boats in place (including DNF or TLE) so that subsequent races may be sailed.

14. HEARINGS

- 14.1. A boat intending to Protest about an incident that occurs in the racing area shall notify the Race Committee via hail or on VHF 72 of her intention, including the sail number of the boat being protested, before leaving the race area. This changes RRS 60.
- 14.2. Protest forms are available in the vicinity of the Jury desk at the FWYC.
- 14.3. The Protest time limit will be posted on the official online notice board.
- 14.4. Protests shall be delivered to a protest committee representative at the FWYC within 45 minutes of the posted docking time of the Race Committee finish boat.
- 14.5. The protest notices required by RRS 63.1(a), and the notification of Protests by the RC or the Protest committee required by RRS 60.2 will be posted on the official notice board as soon as possible after a Protest has been delivered, but not later than 15 minutes after the Protest time limit.

15. REPLACEMENT OF CREW OR EQUIPMENT

- 15.1. Substitution of crews will not be permitted without the prior written approval of the Fleet Liaison (See SI 16).
- 15.2. The same boat, and equipment shall be used throughout the regatta. Boats will be allowed to use two mainsails, two jibs and one spinnaker throughout the regatta. Substitutions will not be permitted without the prior written approval of

the Fleet Liaison.

16. [DP] FLEET LIAISON

- 16.1. The Fleet Liaison for this event will be Greg Griffin. Any comment or concerns regarding on-the-water issues should be directed to the Fleet Liaison. The Fleet Liaison is the only person authorized to discuss on-the-water concerns or issues with the PRO or Race Committee.

17. SAFETY REGULATIONS

- 17.1. Before the first race of each day competitors shall check in by sailing by the stern of the signal boat on starboard tack and hailing their sail numbers until acknowledged by the RC. Failure to check-in shall result in a 20% penalty for the first race of the day without a hearing. This changes RRS 61.4(b)(1).
- 17.2. [DP] A boat that retires from a race shall notify the RC prior to leaving the racing area. If this is not possible, she shall notify the Safety Coordinator, located in the FWYC office upon arriving ashore.

18. RADIO COMMUNICATION

- 18.1. The RC will monitor VHF channel 72 for competitor emergencies, retirements, or compliance with SI 14.1 only.
- 18.2. Communication among RC vessels overheard by a competitor will not be an improper action, nor grounds for redress. This changes RRS 61.4(b)(1).
- 18.3. The RC will use VHF channel 72 to communicate information including the location of the starting area, countdowns, general recalls, postponements and course changes in accordance with SI 11.3. These communications are a courtesy only. Failure of the RC to make, or failure of a boat to hear these broadcasts shall not constitute grounds for granting redress. This changes RRS 61.4(b)(1).
- 18.4. Safety boats will use VHF Channel 72 for safety-related communications.

19. PENALTY SYSTEM

- 19.1. Appendix V is in effect.
- 19.2. Penalties for infractions within the zone of the windward Mark or on the offset leg may be delayed and taken as soon as possible on the downwind leg after clearing the zone. This changes RRS 44.2.
- 19.3. The Protest Committee may impose penalties less than disqualification (DPI), for violation of class rules and racing rules other than those in RRS Part 1 and Part 2 as permitted in RRS 60.5(c)(1) and 60.5(d)(1).

20. ON THE WATER COACHING

- 20.1. On the water coaching by a TCA sanctioned coach will be permitted per TCA Bylaw X paragraph 3b.

21. DISCLAIMER OF LIABILITY

- 21.1. Competitors participate in this regatta at their own risk. See RRS 3, Decision to Race. The Fort Walton Yacht Club, Thistle Class Association, sponsors, Race Committee, Officers and board of directors of FWYC, and all those involved in these organizations will not accept Liability/Responsibility for material damage or personal injury or death sustained in conjunction with or prior to, during and after this regatta.

22. CONTACT INFORMATION

PRO Carl Schellbach 561-714-5902 carl.schellbach@comcast.net

Chief Judge Nancy Parson (404) 355-5900 npparson@gmail.com

Regatta Liaison Greg Griffin (904) 226-0770 thistle3976@gmail.com

Safety Coordinator Paul Beaudry (828) 736-1119

FWYC Fleet Captain, Regatta Chairman William Zehner (850) 305-9653
fleetcaptain@fwyc.org

SI Addendum 1 – Course Charts

Note – Marks as shown below show course configuration only. Actual Mark descriptions are detailed in SI 9.1. Also, the Downwind Finish line (DF) will be adjusted on the water to be approximately perpendicular to the rhumb line from the previous Mark.

Offset Mark (O)   Weather Mark (W)

Reaching Mark (R) 

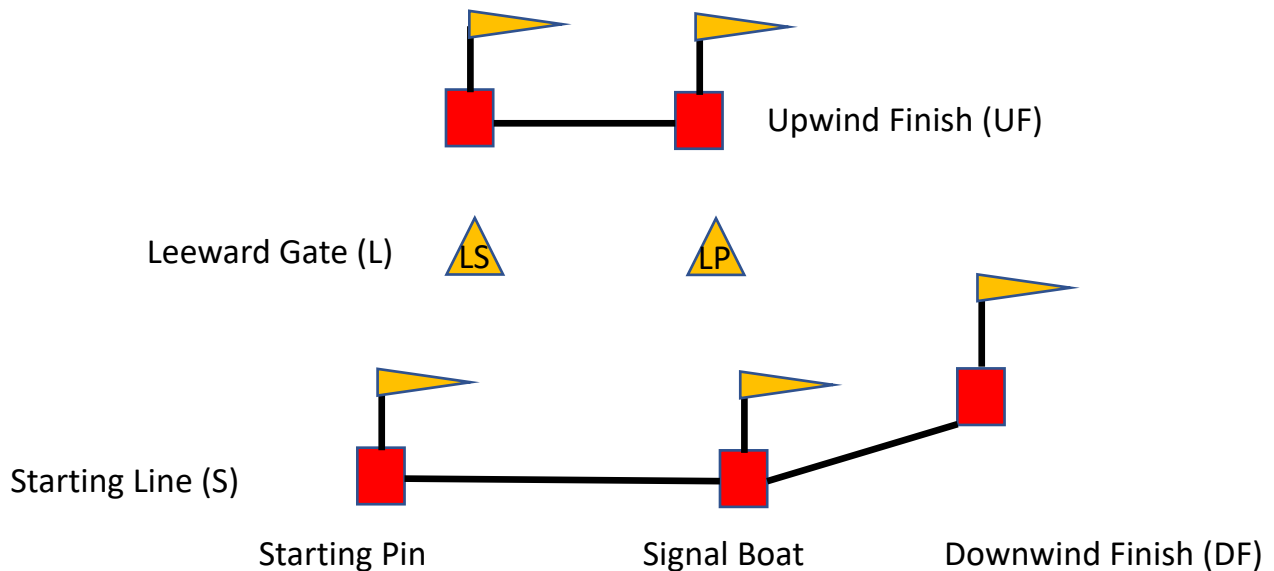

Course 1 – W-O-LS/LP-W-O-LS/LP-UF

Course 2 – W-O-LS/LP-W-R-LS-UF

Course 3 – W-O-LS/LP-W-O-LP-DF

-All Marks left to port except leeward gate

-If only one gate Mark is in place it shall be left to port